

Installation Information

IMPORTANT! READ INSTRUCTIONS PRIOR TO INSTALLATION

Installation Instructions for Fleetline Fenders

1. Consult the Fleetline brochure for the dimensions of the mounting hardware available. The rear bracket (or center bracket on a full fender) dimensions are critical in determining which bracket will fit on a particular truck. Determine the optimum location for the front and rear mounting brackets and in the case of a full fender, the center brackets.
2. Install the brackets as per the schematic shown in the catalogue. Affix all Brackets and posts or side mounts to the frame using grade 8 bolts to firmly secure the brackets. A properly secured arrangement should be satisfactory for 10 years or more.
3. In the case of half and full fenders, use the rubber insulator strips between the surface of the rear or center bracket and the fender. These must be used as they absorb vibration which can lead to cracking of fenders. The rubber strips are manufactured to mate with the ribbed and smooth fender models. Round rubber grommets should not be used. The rear bracket must have a flat surface of 21" by 2" to properly secure the fender, and ensure maximum effectiveness and longevity of the fender. Some rear or center bracket models require a left and right.

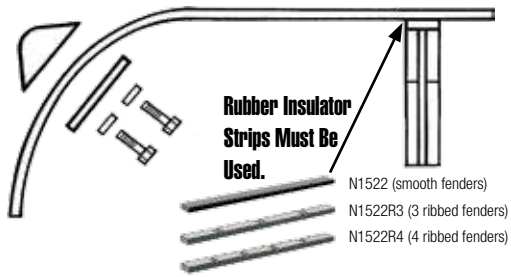

4. The fenders must be positioned so that they are aligned properly. This means that all surfaces must make contact with the brackets without the fender requiring any twisting or bending. Should the fender require twisting to attach it to the brackets, you risk premature unwarranted failure.
5. Drill the holes in the fenders as needed. Three bolts should be used when the fenders are attached to the rear brackets or center brackets. When using the mounting kits containing the rear brackets or center brackets mounting arms there is an installation template included for this purpose.
6. Use only stainless steel hardware when installing Fleetline Tandem Fenders. The hardware supplied in the mounting kits is stainless steel. Failure to use only stainless steel hardware could result in premature staining of stainless steel fenders.
7. Secure the fenders firmly on the mounting arrangement using the stainless hardware provided in the mounting kits.
8. In order to keep the fenders clean with a good appearance, clean only with mild soap and water. Do not use harsh or gritty cleaners or acids as they could tarnish the surface of fenders.

QUARTER FENDER INSTALLATION GENERAL INSTRUCTIONS

A qualified mechanic should perform installation. Failure to follow these installation instructions could create a condition resulting in product damage. Recommended fender mounting will result in maximum fender and flap life.

1. Lay a straight edge across the truck frame, locate the top of the fender flap a minimum of 2 inches below the top of the fifth wheel to prevent damage to the fender from the trailer.
2. Allow a minimum of 3 inches clearance between the tire and the fender. Mount quarter fender so that the top of the rubber flap is lower than the top level of the fifth wheel.
3. Slide the fender all the way onto the mount before clamping. Depending on the vehicle application, the width across the fenders should be 95 inches and/or the outside edge of the fender should line up with the outboard side of the tire.
4. Rotate the fender until the top flap is near vertical and locate the clamp on the center of tube slot. Tighten clamp to approximately 150 ft/lbs.
5. If the fender model includes an end cap, install the cap in the end of the tube.
6. After a vehicle shake down test, check all bolts for tightness.
7. Check all nuts, bolts, and clamps for tightness during regular maintenance of the vehicle.

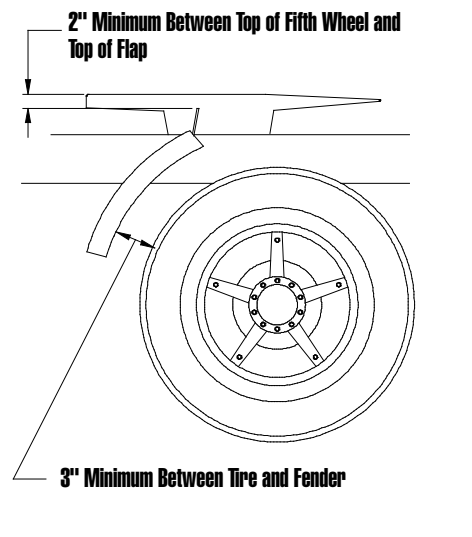

Allow 3 inches minimum between the fender edge and the tire. Recommended fender mounting will result in maximum fender and flap life. If the fender is mounted too close to the bottom of the trailer, it may cause the fender to be damaged by flexing into the tire when the trailer tips and forces the top of the fender down.



800-332-6653

www.fleetlineproducts.com